

Couplings & Trailer Support

Couplings for braked & unbraked trailers • Jockey wheels • Propstands

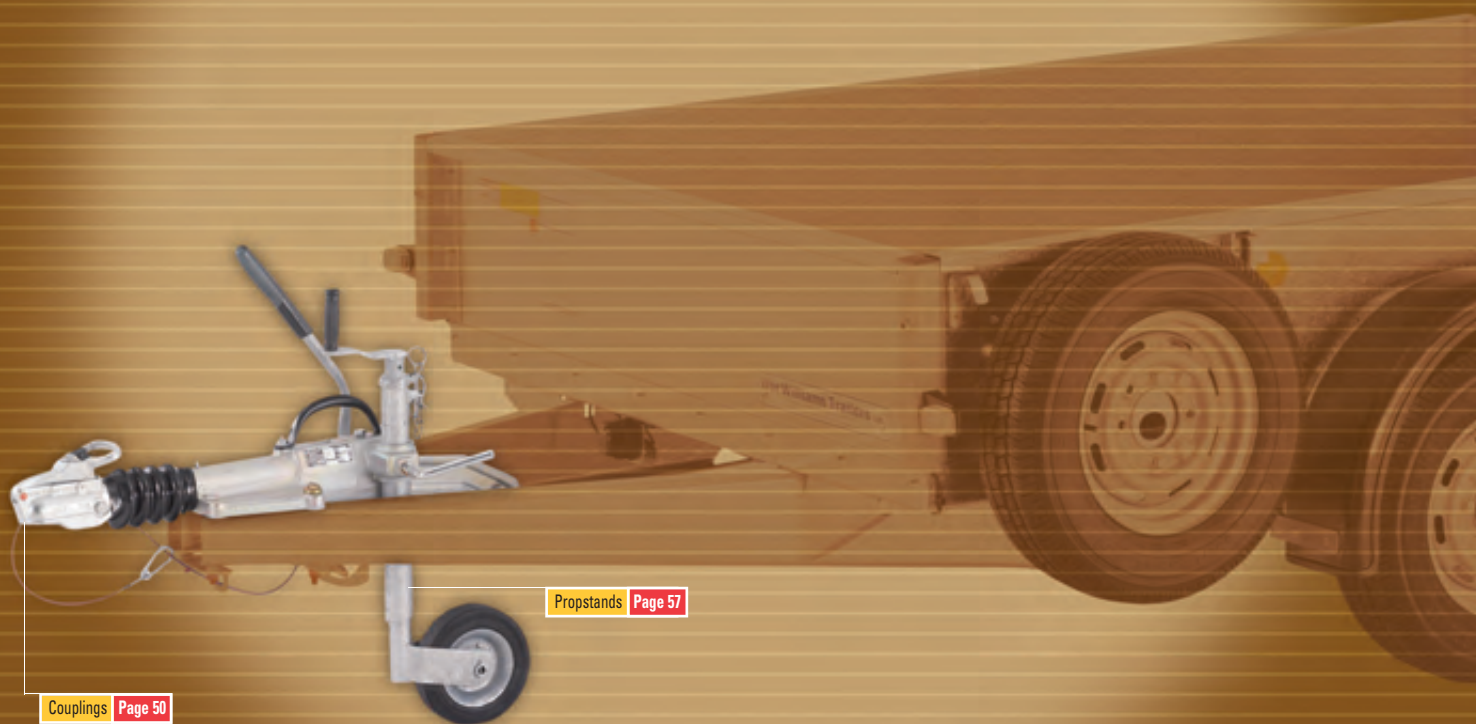

Contents	Page
Unbraked couplings including dedicated coupling locks, up to 750KG GVW	50
Knott KF13 & KF13E hydraulically damped overrun couplings 750-1400Kg GVW	51
Knott KFG27 hydraulically damped overrun couplings 1400-2700Kg GVW	52
Knott KFG35 hydraulically damped overrun couplings 2700-3500Kg GVW	53
Knott KRV20, KF20 & KFG20 hydraulically damped overrun couplings 1100-2000Kg GVW	54
Al-Ko 251s coupling hydraulically damped overrun couplings 1500-2600Kg GVW	55
Bradley Couplings	56
Propstands (tubular), jockey wheels, jockey spares, clamps and brackets	57
Bolt on propstands and spigots for the LT/LM, beavertail or tilt-bed trailer ranges	58

P00280 Unbraked Coupling assembly KZE 7.5.110 – 120mm centres. High rear bracket. Pressed steel head Used on the unbraked Eurolight range.

P00355LDB Coupling/Drawbar. Swan neck style drawbar and coupling head. Used on the P5 Range.

P00355DB Coupling/Drawbar. Swan neck style drawbar and coupling head used on the BV64E & P6E Range.

P00355DB2 Coupling/Drawbar. Swan neck style drawbar and coupling head used on the P7E Range.

1 P00355 Coupling Head. 750kg GVW, 50mm ball pressed steel head. Fitted to the P5, P6E, P7E and unbraked Eurolight.

2 P0150 Coupling Head. 750kg 50mm ball, cast iron coupling head. Used on older P6E drawbars.

3 P00366 Hitch Lock. Fits over the groove on the P00355 coupling head, blocking access to the ball.

4 P00354* Slider lock. Fits within the sliding bolt aperture on the P00355 head to prevent operation of the handle, can also be used when coupled to car.

5 P00368 Barrel lock (Bradley). Fits into a hole in P0150 coupling heads preventing operation of the handle.

P00355SC Secondary coupling cable. Used with P00355 unbraked coupling head.

* Visual deterrent only



See page 73 for other security products including locks for the braked couplings



EYE MAY DIFFER FROM THE PHOTOGRAPH

A change to the bolt spacing to 120mm on the KF 13 coupling has just been introduced. It has affected the following trailer range.
P6/P8 Week commencing 13/04/2009
GD64, GD84SA & GD85SA Week commencing 13/0/04/2009
BV84SA & BV85SA. Week commencing 13/04/2009
 If a replacement coupling is required for an older model then please use the P00330 KFG20 coupling – please see page 54.

- 1 P00317-120 KF13 Coupling unit (pressed steel body).** 750-1400kg GVW Hydraulically damped overrun coupling unit, incorporating energy store handbrake for use with autoreverse brakes and 50mm ball hitch. 120mm bolt spacings. Introduced into production April 2009, not compatible with older trailers. Used on the trailer range listed above.
- P00307 Coupling Unit KF13E.** 1400kg 120mm centres. High rear bracket. Pressed steel head. Used on the Eurolight range EL101-2012, 2512, 2515, EL141-2515, EL142-2512, 2515, 3015, 3615
- 2 P00301 Coupling head.** Replacement low profile 50mm coupling head for the KF13 coupling. Includes the lock and two keys. Requires P00939 packing shim.
- P003075 Pressed steel Coupling head KF13E.** To fit 45mm drawtube. Lockable with a padded grip. For the P00307 Coupling. Used on the Eurolight range. Requires P00939 packing shim.
- P00939 Packing Shim.** Fits under the coupling heads P00301 & P003075.
- 3 P00302 Lock insert.** Replacement lock for the Avonride coupling head. KF13 coupling.
- 4 P00303 Cover cap.** Protects the Avonride coupling head lock from ingress of dust and water. KF13 coupling.
- 5 P00318C 30mm Eye Kit.** Includes all mounting hardware.
- 6 P00333 40mm Eye Kit.** Includes all mounting hardware.
- P00369 Bellows.** Replacement protective bellows.
- 7 P00937 Damper.** Replacement hydraulic damper for KF13, KF13E
- 8 P00936 Damper bracket.** Holds one end of the damper rod within the body of the coupling.
- 9 P00938 Drawtube.** Includes stop ring.
- 10 P00931 Powered handbrake upgrade kit.** Complete with oil-damped spring pack, handbrake lever and all mounting hardware etc.
- P00929 Oil damped spring pack.**
- P00928 Hand Brake lever assembly.**
- 11 P00940 Overrun lever.** Fitted to the rear of the coupling unit, this lever creates the pull on the brake rod.

- 12 P00363 Clamp handle.** Short jockey wheel clamp handle.
- 13 P00399 Retainer pad.** Fits within the recess in the overrun unit to securely clamp the jockey wheel.
- 14 P00387 Breakaway cable spring ring type.** It is recommended that you carry a spare breakaway cable whenever you tow.
- 15 P00899 Breakaway cable clevis type.** For more recent knott couplings having this type of cable fitted originally.

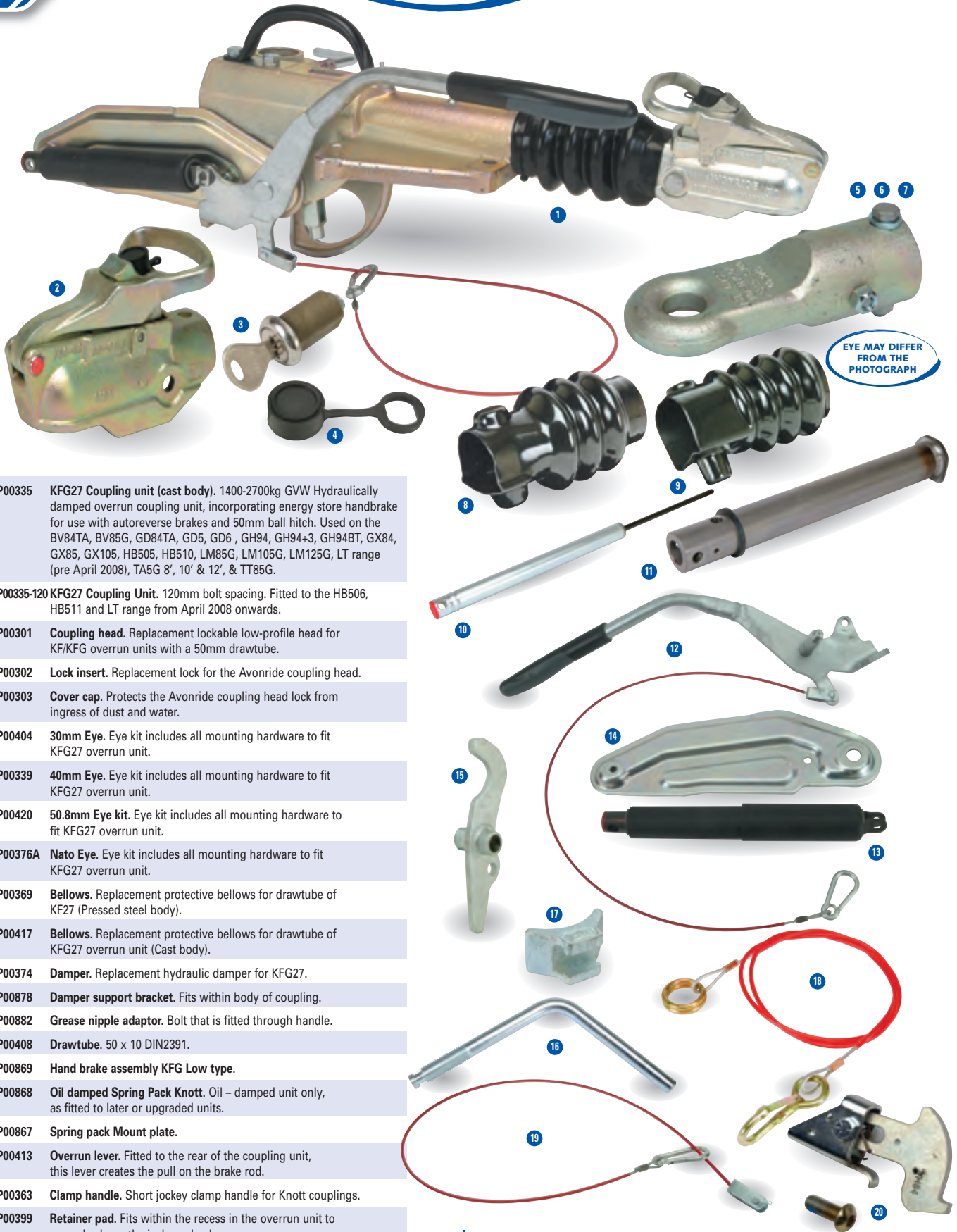

EYE MAY DIFFER FROM THE PHOTOGRAPH

1 P00335 KFG27 Coupling unit (cast body). 1400-2700kg GVW Hydraulically damped overrun coupling unit, incorporating energy store handbrake for use with autoreverse brakes and 50mm ball hitch. Used on the BV84TA, BV85G, GD84TA, GD5, GD6, GH94, GH94+3, GH94BT, GX84, GX85, GX105, HB505, HB510, LM85G, LM105G, LM125G, LT range (pre April 2008), TA5G 8', 10' & 12', & TT85G.

P00335-120 KFG27 Coupling Unit. 120mm bolt spacing. Fitted to the HB506, HB511 and LT range from April 2008 onwards.

2 P00301 Coupling head. Replacement lockable low-profile head for KF/KFG overrun units with a 50mm drawtube.

3 P00302 Lock insert. Replacement lock for the Avonride coupling head.

4 P00303 Cover cap. Protects the Avonride coupling head lock from ingress of dust and water.

5 P00404 30mm Eye. Eye kit includes all mounting hardware to fit KFG27 overrun unit.

6 P00339 40mm Eye. Eye kit includes all mounting hardware to fit KFG27 overrun unit.

P00420 50.8mm Eye kit. Eye kit includes all mounting hardware to fit KFG27 overrun unit.

7 P00376A Nato Eye. Eye kit includes all mounting hardware to fit KFG27 overrun unit.

8 P00369 Bellows. Replacement protective bellows for drawtube of KF27 (Pressed steel body).

9 P00417 Bellows. Replacement protective bellows for drawtube of KFG27 overrun unit (Cast body).

10 P00374 Damper. Replacement hydraulic damper for KFG27.

P00878 Damper support bracket. Fits within body of coupling.

P00882 Grease nipple adaptor. Bolt that is fitted through handle.

11 P00408 Drawtube. 50 x 10 DIN2391.

12 P00869 Hand brake assembly KFG Low type.

13 P00868 Oil damped Spring Pack Knott. Oil - damped unit only, as fitted to later or upgraded units.

14 P00867 Spring pack Mount plate.

15 P00413 Overrun lever. Fitted to the rear of the coupling unit, this lever creates the pull on the brake rod.

16 P00363 Clamp handle. Short jockey clamp handle for Knott couplings.

17 P00399 Retainer pad. Fits within the recess in the overrun unit to securely clamp the jockey wheel.

18 P00387 Breakaway cable spring ring type. It is recommended that you carry a spare breakaway cable whenever you tow.

19 P00899 Breakaway cable clevis type. For more recent knott couplings having this type of cable fitted originally.

20 P00915 Manual reverse kit. While the basic reversing function remains automatic, this kit allows easier reversing up steep hills or on poor surfaces, where traction can sometimes be a problem. Please note Can only be fitted to the KFG27 coupling manufactured from late 2005 that has slot fitted as standard.



- 1 P00340 **KFG35 Coupling unit (cast body).** 2700-3500Kg GVW Hydraulically damped overrun coupling unit, incorporating energy store handbrake for use with autoreverse brakes and 50mm ball hitch. Used on the BV6 range, CT166, CT167, CT177, DP range, GH1054BT, GP 6 range, GX105HD, GX125HD, GX106, GX106N, GX126, HB510XL, HB610, LM105GHD, LM125GHD, LM106G, LM126G, LM146G/GB, LM166G/GB, TA5GHD, TA510G 10',12' & 14', TT105G & TT126G
- 2 P00907 **Coupling head.** Replacement lockable low-profile head for KF/KFG overrun units with a 60mm drawtube.
- 3 P00302 **Lock insert.** Replacement lock for the Avonride coupling head.
- 4 P00303 **Cover cap.** Protects the Avonride coupling head lock from ingress of dust and water.
- 5 P00402 **30mm Eye.** Eye kit includes all mounting hardware to fit KFG35 overrun unit. *
- 6 P00401 **40mm Eye.** To fit the KFG35 overrun unit. *
- P00421 **50.8mm Eye kit.** Eye kit includes all mounting hardware to fit KFG35 overrun unit.
- 7 P00920 **Nato Eye.** Towed by Nato style towing jaw, can be fitted to the KFG35 in place of the existing eye or head.
- 8 P00873 **Bellows.** Replacement protective bellows for drawtube of KFG35 overrun unit.
- 9 P00400 **Damper.** Replacement hydraulic damper for KFG35.
P00878 **Damper support bracket.** Fits within body of coupling.
P00882 **Grease nipple adaptor.** Bolt that is fitted through handle.
- 10 P00871 **Drawtube.** For the KFG35 overrun unit.
- 11 P00869 **Hand brake assembly KFG Low type.**
- 12 P00868 **Oil damped Spring Pack Knott.**
- 13 P00867 **Spring pack Mount plate.**
- 14 P00885 **Overrun lever.** Fitted to the rear of the coupling unit, this lever creates the pull on the brake rod.
- 15 P00364 **Clamp handle.** Long jockey clamp handle for Knott couplings.
- 16 P00399 **Retainer pad.** Fits within the recess in the overrun unit to securely clamp the jockey wheel.
- 17 P00387 **Breakaway cable spring ring type.** It is recommended that you carry a spare breakaway cable whenever you tow.
- 18 P00899 **Breakaway cable clevis type.** For more recent knott couplings having this type of cable fitted originally.
- 19 P00915 **Manual reverse.** For KFG35 Overrun units. While the basic reversing function remains automatic, this kit allows easier reversing up steep hills or on poor surfaces, where traction can sometimes be a problem.

EYE MAY DIFFER FROM THE PHOTOGRAPH

* Bellows included with this part



P00308 Coupling unit KF20A. 120mm centres. Lockable pressed steel head. High rear bracket. Used on the Eurolight range EX202-2515, 3015 & 3615.

1 P00320 KRV20 Coupling unit (pressed steel body) for 100mm square tube drawbars. 1100-2000Kg GVW Hydraulically damped overrun coupling unit, incorporating energy store handbrake for use with autoreverse brakes and 50mm ball hitch. Used on the HB401 & HB403.

P00330 Coupling unit KFG20. Weight range 1100 – 1200kg. 50mm lockable low profile coupling head. Used on the GH64 and as a replacement coupling for the KF13 (pre April 2008).

2 P00301 Coupling head. Replacement lockable low-profile head for the KFG20 & KRV20 couplings.

P003085 Coupling head. Replacement head for the KF20 coupling.

3 P00302 Lock insert. Replacement lock for the Avonride coupling head. Used on the Avonride head fitted to the KFG20 & KRV20 coupling units.

4 P00303 Cover cap. Protects the Avonride coupling head lock from ingress of dust and water. Used on the Avonride head fitted to the KFG20 & KRV20 coupling units.

5 P00318C 30mm Eye Kit. Includes all mounting hardware.

6 P00333 40mm Eye Kit. Includes all mounting hardware.

7 P00369 Bellows. Replacement protective bellows.

8 P00373 Damper. Replacement hydraulic damper.

P00936 Damper Bracket. Holds one end of the damper within the body of the coupling unit.

9 P00938 Drawtube.

10 P00413 Overrun lever. Fitted to the rear of the coupling unit, this lever creates the pull on the brake rod.

11 P00868 Spring pack. Oil damped unit only, as fitted to later or upgraded units. Used on the KFG20 coupling unit.

P00929 Spring pack. Oil damped spring pack unit only. Used on the KF20 & KRV20 coupling units.

12 P00869 Hand Brake assembly. KFG low type. Used on the KFG20 coupling.

P00928 Hand Brake assembly.

13 P00363 Clamp handle. Jockey clamp handle.

14 P00399 Retainer pad. Fits within the recess in the overrun unit to securely clamp the jockey wheel.

15 P00387 Breakaway cable spring ring type. It is recommended that you carry a spare breakaway cable whenever you tow.

16 P00899 Breakaway cable clevis type. For more recent knott couplings having this type of cable fitted originally.

EYE MAY DIFFER
FROM THE
PHOTOGRAPH

251S

Used on the
HB505 up to
September 1992

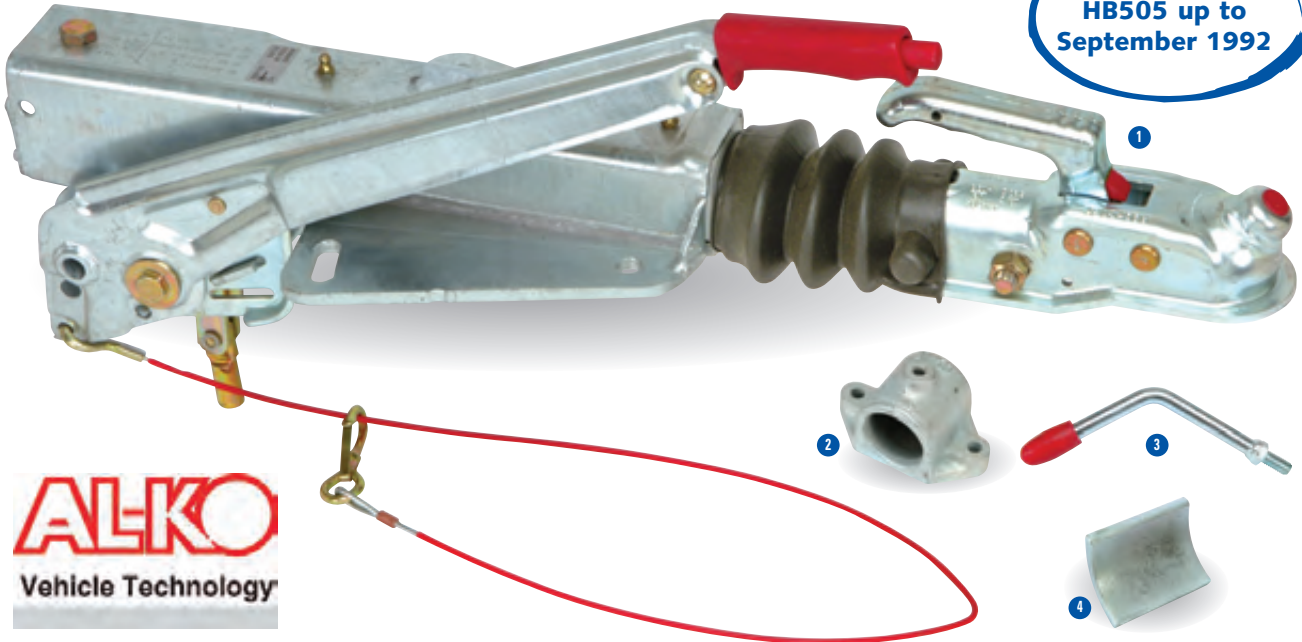

ALKO
Vehicle Technology

- 1 P0515 251S Coupling unit. 1500-2600Kg GVW Hydraulically damped overrun coupling unit, incorporating gas sprung handbrake for use with autoreverse brakes and 50mm ball.
 - 2 P0549 Jockey Bracket. Type 295-191 this is used on the 251s overrun unit.
 - 3 P0549H Clamp handle. For the 295-191 Bracket.
 - 4 P0549P Pad. Fits within the recess in the 295-191 Bracket to clamp against the jockey wheel tube.
 - 5 P0542 Damper. Old Type. (325mm Centres).
 - 6 P0542A Damper. New Type. (505mm Centres).
 - 7 P0528 Head. Replacement coupling head for 251's overrun unit.
 - 8 P0551 Bellows. For the 251s overrun unit.
 - 9 P0545 Brake lever. For the 251s overrun unit.
 - 10 P0548 Outer clamp. Outer part of Jockey wheel clamp on 251S overrun unit.
 - 11 P0552 Manual reverse kit. For the 251s overrun unit.
 - 12 P00387 Breakaway cable. It is recommended that you carry a spare breakaway cable whenever you tow.
- P0521 Lock. Al-ko barrel lock.
- P0554 Knob. For the Al-ko jockey wheel head.

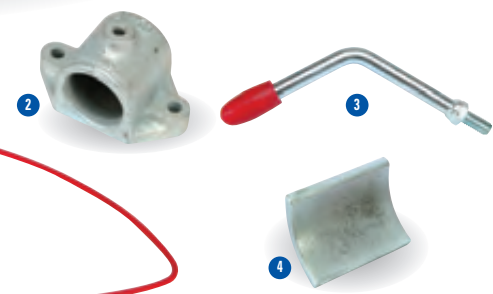
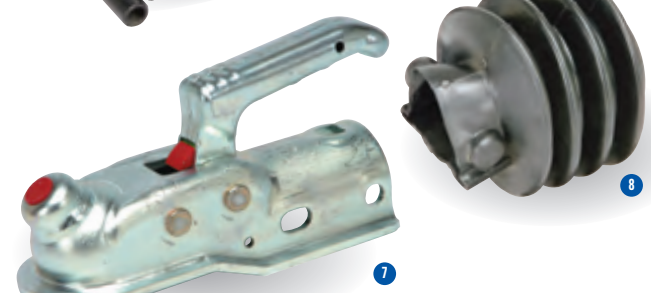
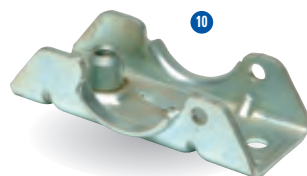
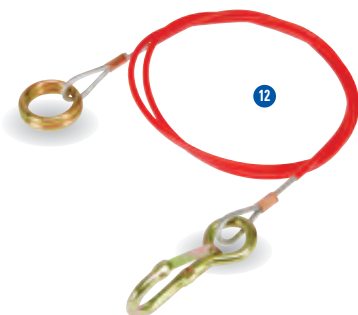

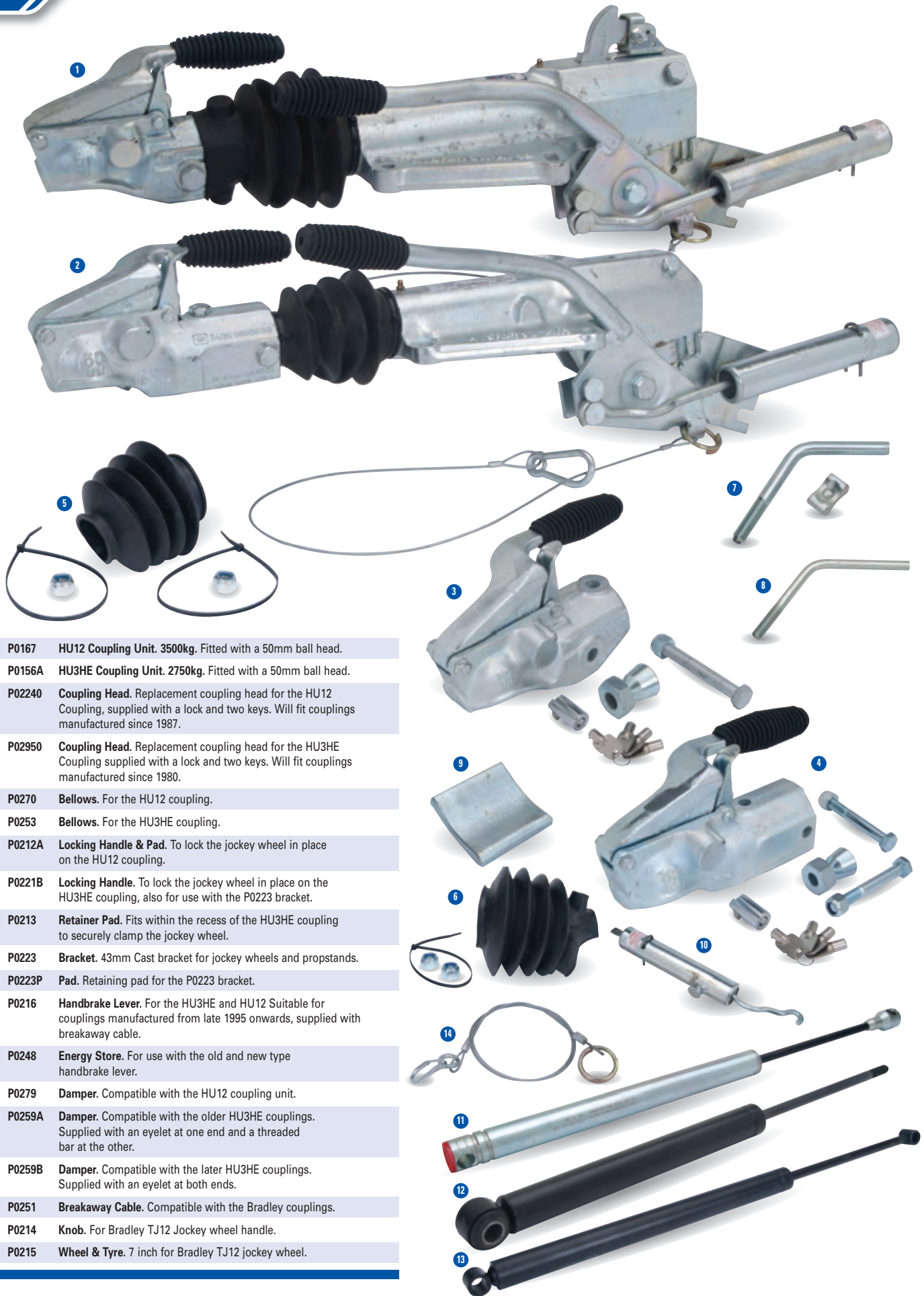

- 1 P0167 HU12 Coupling Unit. 3500kg.** Fitted with a 50mm ball head.
- 2 P0156A HU3HE Coupling Unit. 2750kg.** Fitted with a 50mm ball head.
- 3 P02240 Coupling Head.** Replacement coupling head for the HU12 Coupling, supplied with a lock and two keys. Will fit couplings manufactured since 1987.
- 4 P02950 Coupling Head.** Replacement coupling head for the HU3HE Coupling supplied with a lock and two keys. Will fit couplings manufactured since 1980.
- 5 P0270 Bellows.** For the HU12 coupling.
- 6 P0253 Bellows.** For the HU3HE coupling.
- 7 P0212A Locking Handle & Pad.** To lock the jockey wheel in place on the HU12 coupling.
- 8 P0221B Locking Handle.** To lock the jockey wheel in place on the HU3HE coupling, also for use with the P0223 bracket.
- 9 P0213 Retainer Pad.** Fits within the recess of the HU3HE coupling to securely clamp the jockey wheel.
- P0223 Bracket.** 43mm Cast bracket for jockey wheels and propstands.
- P0223P Pad.** Retaining pad for the P0223 bracket.
- P0216 Handbrake Lever.** For the HU3HE and HU12 Suitable for couplings manufactured from late 1995 onwards, supplied with breakaway cable.
- 10 P0248 Energy Store.** For use with the old and new type handbrake lever.
- 11 P0279 Damper.** Compatible with the HU12 coupling unit.
- 12 P0259A Damper.** Compatible with the older HU3HE couplings. Supplied with an eyelet at one end and a threaded bar at the other.
- 13 P0259B Damper.** Compatible with the later HU3HE couplings. Supplied with an eyelet at both ends.
- 14 P0251 Breakaway Cable.** Compatible with the Bradley couplings.
- P0214 Knob.** For Bradley TJ12 Jockey wheel handle.
- P0215 Wheel & Tyre.** 7 inch for Bradley TJ12 jockey wheel.



- 1 **P0475 Jockey wheel 48mm.** Heavy duty ribbed shaft design and heavy duty tyre. Suits the Bradley HU12, Knott KFG35 couplings or the P0209 clamp.
- 2 **P0475H Jockey wheel 48mm.** Heavy duty version with extended slimline handle for extra clearance against winch brackets. Fitted with the P04751 tyre.
- 3 **P0474 Jockey wheel 48mm.** Medium duty smooth stem design, suits the Knott KF13, KF13E, KF20, KFG20, KRV20 KFG27 & Alko P0515 couplings.
- 4 **P0476 Jockey wheel 42mm.** Standard duty smooth stem design, suits the Bradley HU3H & HU3HE couplings.
- 5 **P0567 Jockey wheel 35mm.** Suits the P00280 Unbraked Eurolight coupling and the P5,P6E, P7E & BV64E when The front prop stand is removed.

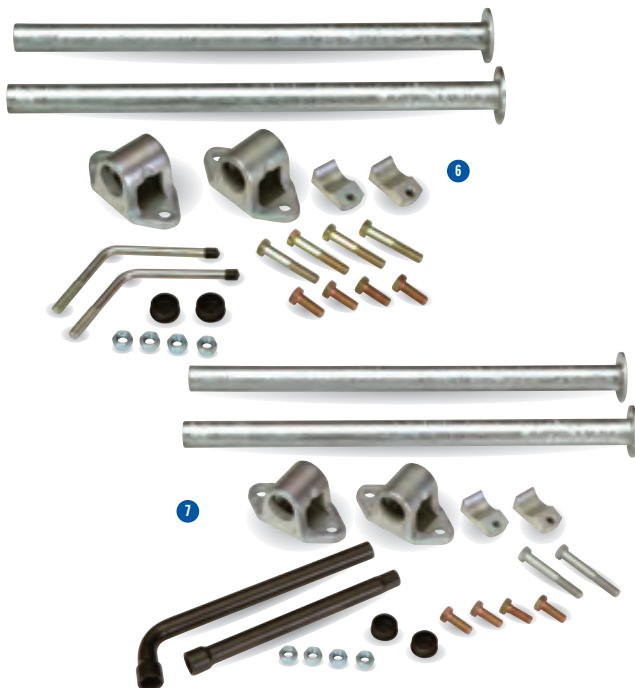

- KX0230 **Propstand kit.** Pair of propstands for Maxi-plant trailers.
- 6 KX0221 **Propstand kit.** Pair of propstands for the GD range.
- 7 KX0222 **Propstand kit.** Pair of propstands for the Box Van and Horsebox range.
- KX0225 **Propstand kit.** Pair of propstands for the P5, P6E & P7E range.
- KX0232 **Propstand kit.** Pair of propstands for HB510XL.
- KX0233 **Propstand kit.** Pair of propstands for the HB403, HB506 & HB511.

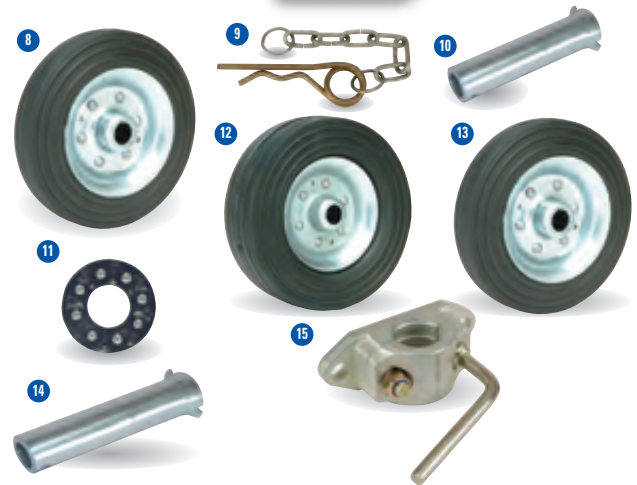

- 8 **P04741 Wheel.** Wheel and tyre 52mm wide x 200mm diameter. Suits P0474 & P0476 Jockey wheels.
- 9 **P04743 R clip.** Includes chain, as fitted to P0474, P0475 & P0476.
- 10 **P04744 Axle tube.** Fits items 3 & 4.
- 11 **P04745 Thrust bearing unit.** Fits between inner and outer stem of P0475, P0475H, P0474 & P0476 Jockey wheels.
- 12 **P04751 Wheel.** Wheel and tyre 75mm wide x 235mm diameter. Suits the older P0475 Jockey wheels and P0475H Jockey wheels.
- 13 **P04752 Wheel.** Wheel and tyre 60mm wide x 210mm diameter. Suits the current P0475 Jockey wheel
- 14 **P04754 Jockey wheel axle.** For the wide tyre fitted to heavy duty ribbed jockey wheels.
- P0214 **Knob.** For Bradley TJ12 Jockey wheels (originally supplied with the CU and HU series couplings).
- P0215 **Wheel.** Wheel and tyre for the Bradley TJ12 jockey wheel.
- 15 **P0209 Clamp bracket.** Complete clamp bracket for all our ribbed heavy duty jockey wheels & propstands.
 - P0209SP **Split pin.** Fitted through top of heavy duty prop stand.
 - P0209H **Handle.** For heavy duty prop stand clamp.
 - P0209N2 **Nut M16.** (Clamp nut used in the P0209 bracket).
- P0221 **Propstand bracket.** Mounting bracket for 35mm propstand or jockey wheel, requires pad and handle to complete.
 - P0221P **Retainer pad.** Fits within the recess of the P0221 bracket.
 - P0221H **Clamp handle.** M12 for metric propstand clamps.
- P0223 **Jockey bracket.** P200 bracket for fitting 42mm diameter jockey wheels or propstand tubes.
 - P0223P **Pad.** For bracket P0223.
 - P0221B **Clamp handle.** 1/2" For the P0223 Bracket.
- P0288 **Clamp handle.** Locking handle for HU10 Overrun units or TJ15 Jockey wheel.



- 16 **AS5875 Propstand.** The propstand used on the P5, P6E & P7E models (does not include the bracket) 460mm.
- AS5874 Propstand.** The propstand used on the Boxvan, GD and Horsebox range (does not include the bracket) 560mm.
- P0197 **Propstand (Individual).** 590mm. (With serrated shaft). Used on the BV6 range.
- 17 **P0199 Propstand (Individual).** 508mm. (With serrated shaft). Used on the GD Major range.
- P0200 Propstand (Individual).** 350mm. (With serrated shaft). Used on the GP range.

Couplings & Trailer Support

Bolt On Propstands

1 KX0227 Propstand kit. Pair of propstands for LT/LM models complete with pair of bolt-on spigots and full fitting kit.

P1114 Propstand. Individual propstand for LT/LM models (350mm tube).

2 P1115/P Pin assembly. Pin assembly for propstands on LT/LM models.

3 P11170G Spigot. Bolt on propstand spigot for LT/LM models (includes mounting hardware).

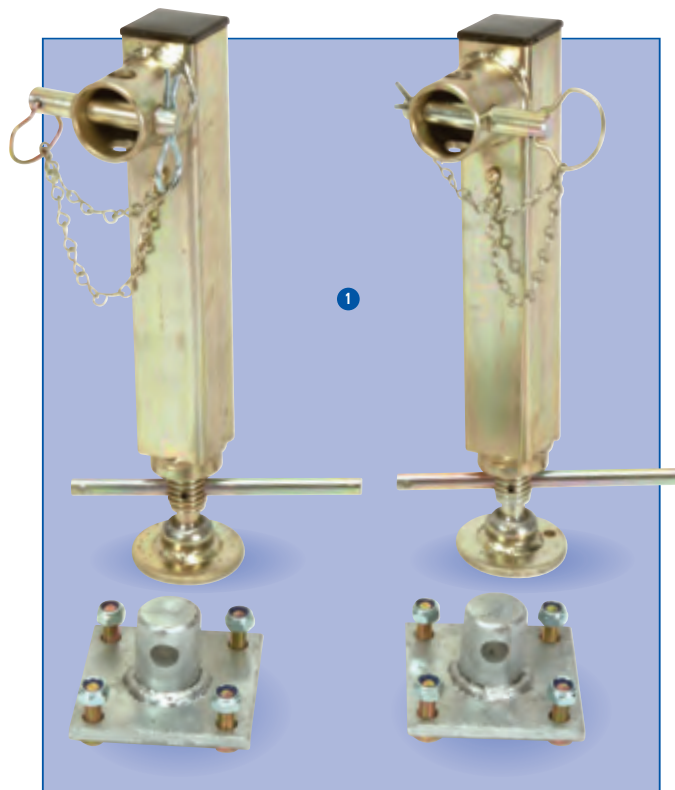

LM146 with headboard, dropsides, meshsides, ramp and prop stands.